

QUICK GUIDE FOR THE CORRECT MAINTENANCE

DAILY

BEFORE THE USE

CHECK THE BRUSH AND THE SQUEEGEE:

Check that the brush and the squeegee are clean. Check the correct fixing of the brush and the squeegee rubbers.

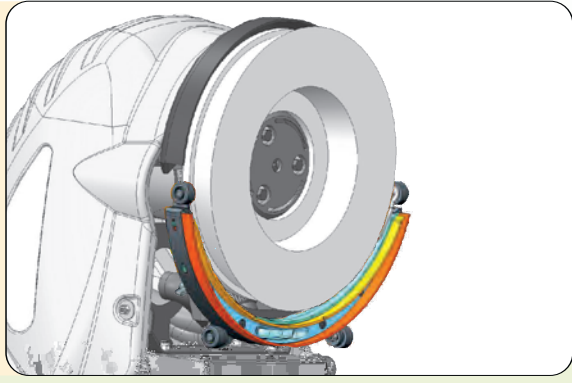

PREPARE THE MACHINE:

Bring the machine to the working position and so the handle bar. Fill the solution tank with water and add the detergent liquid in the percentage recommended.

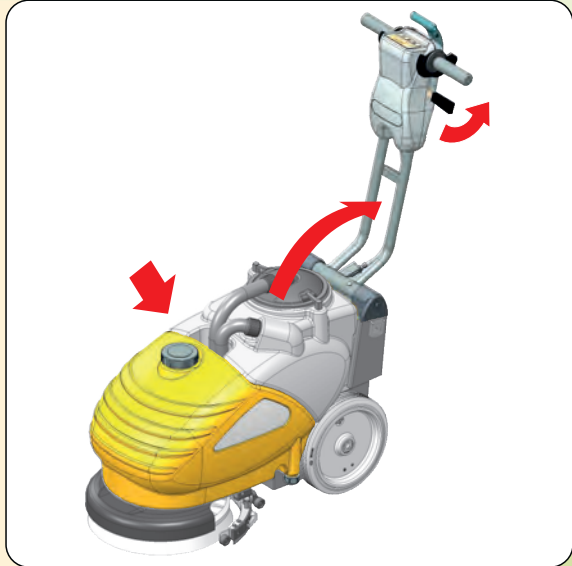

CONNECT THE BATTERIES:

Turn the blocking levers to take off the filter. Remove the coupler of the squeegee hose and take off the recovery tank.

AGM: connect the two connectors.

XFC: connect the connector.

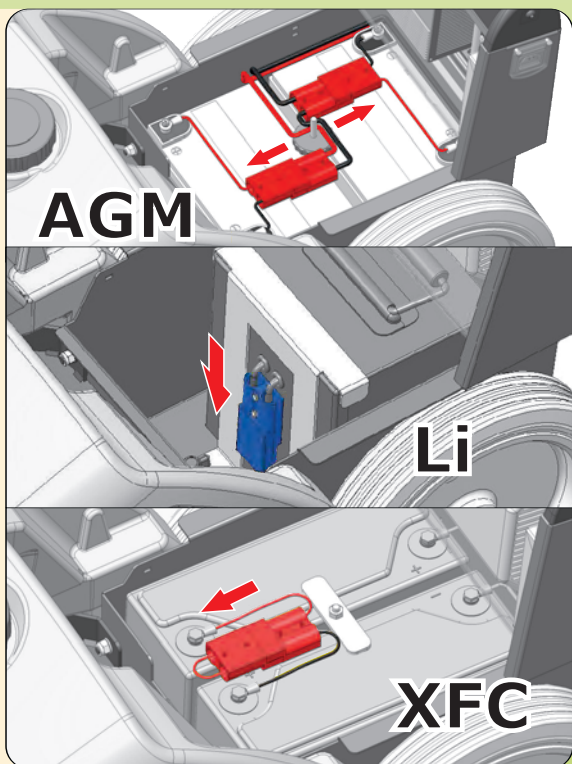

CHECK THE CHARGE LEVEL OF THE BATTERIES:

AGM: when the orange signal comes on, it is necessary to charge the batteries (with the red signal on, the machine will stop).

XFC: when the green signal blinks, it is necessary to charge the batteries (with the red signal on, the machine will stop).

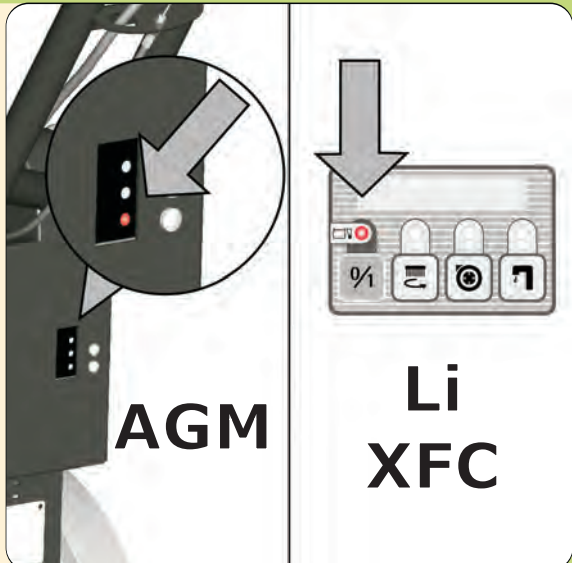

CHARGE ALWAYS THE BATTERIES:

NEVER LEAVE THE BATTERIES DISCHARGED! PROVIDE FOR THEIR IMMEDIATE RECHARGING. IF A LONGER STOP OF THE MACHINE IS EXPECTED, DISCONNECT ALWAYS THE BATTERIES.

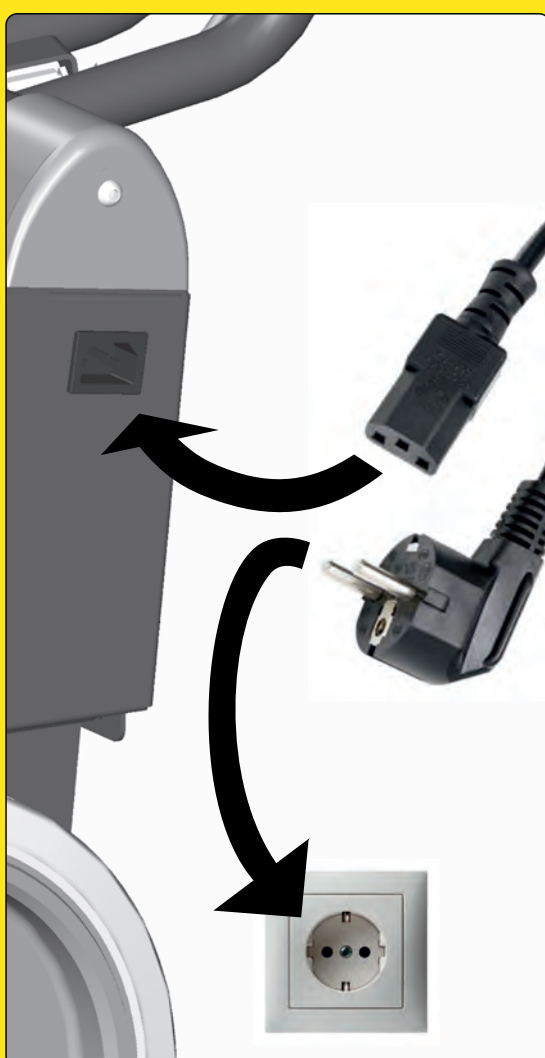
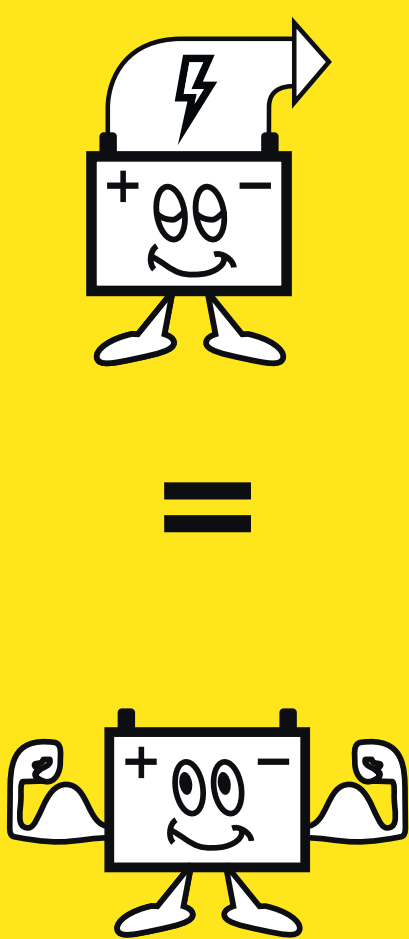

AFTER THE USE

EMPTY AND CLEAN THE RECOVERY TANK:

Turn the blocking levers to take off the filter. Remove the coupler of the squeegee hose and take off the recovery tank to empty and to rinse it.

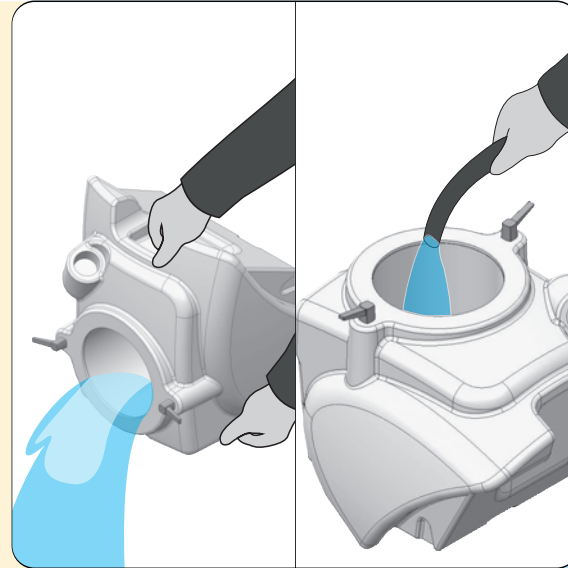

EMPTY AND RECOVER THE REMAINING DETERGENT SOLUTION:

Unscrew the lower plug to recover in appropriate containers the detergent solution in excess. Avoid leaving it in the tank for too long. Clean the upper tank filter. Clean the machine with a damp cloth.

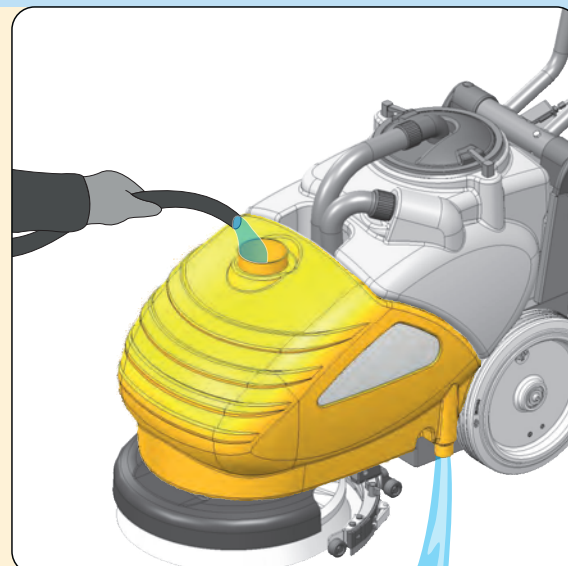

CLEAN THE SUCTION FILTER:

Take off the filter with the float bending the filter edge to release it from the screws present on the cover. Clean all parts with a water jet, reassemble everything once more. Never use the machine without the filter.

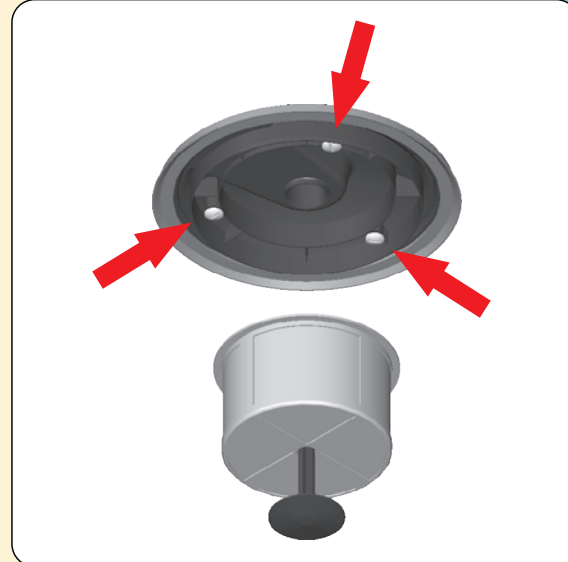

VERTICAL POSITIONING OF THE MACHINE:

After having emptied and cleaned both tanks, fold the handle bar forwards. Rotate the machine on the rear wheels by lifting the front part in point A and B, bringing it into the vertical position.

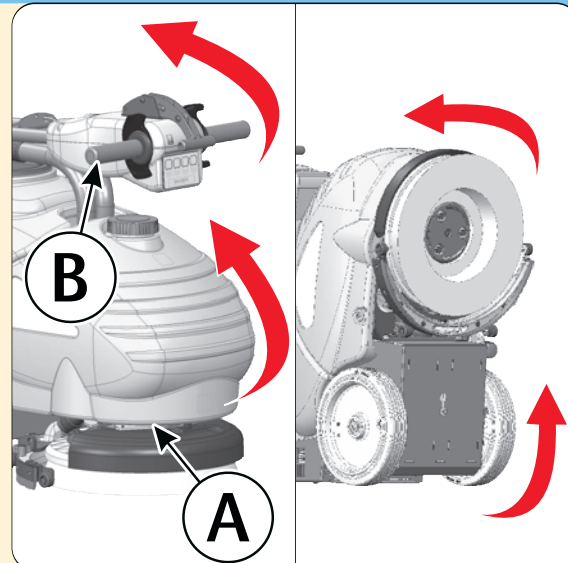

CLEAN THE SQUEEGEE:

Clean the rubbers and the suction inlet to remove eventual residuals of dirt.

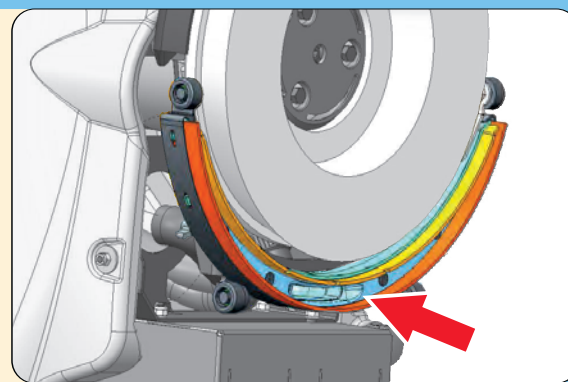

REMOVE AND CLEAN THE BRUSH:

Rotate the brush clockwise until it is released. Clean with a water jet and reassemble it again.

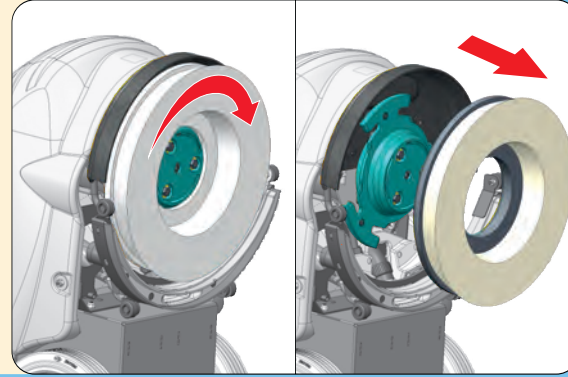

WEEKLY

CHECK THE REAR SQUEEGEE RUBBER:

Check the squeegee rubber wear and if necessary, turn or replace it.

- Unscrew the wing nuts and take off the squeegee.

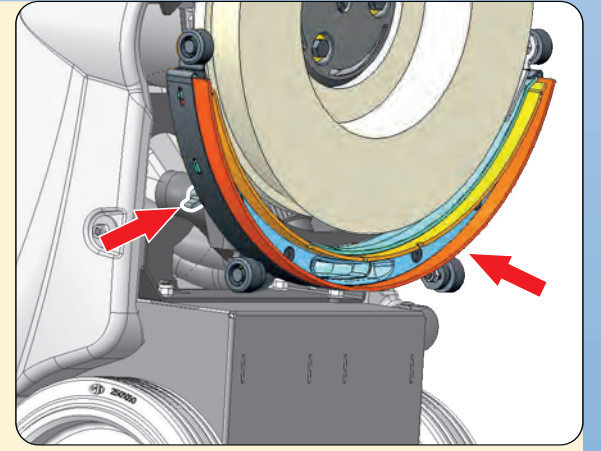

- Release the catch of the rubber holder blade.

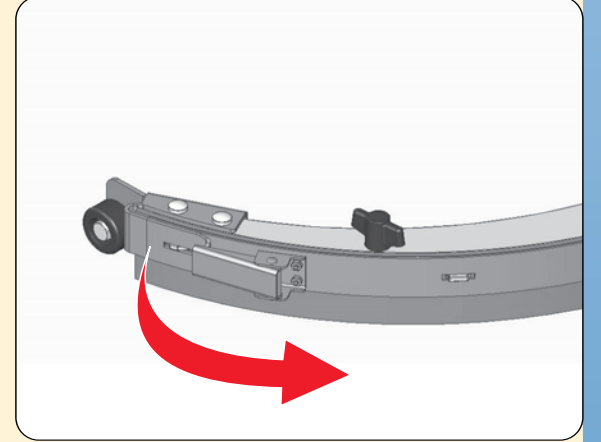

- Take off the rubber.

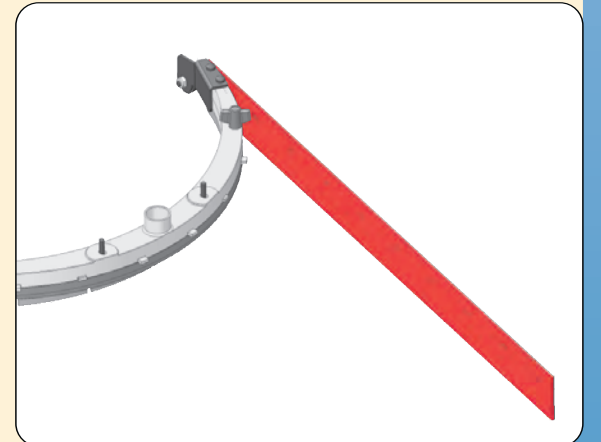

CHECK THE FRONT SQUEEGEE RUBBER:

Check the rubber wear and eventually replace it. Unscrew the wing nuts and separate the two metal parts that form the squeegee body. Take off the rubber.

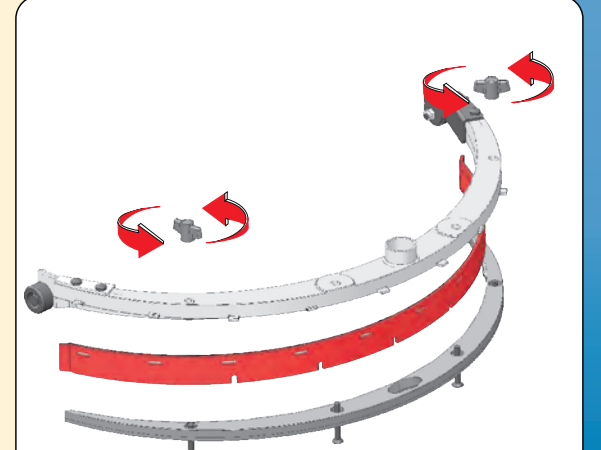

WHEN NECESSARY

ADJUST THE DETERGENT SOLUTION FLOW ONTO THE FLOOR:

If necessary, modify the detergent solution quantity on the floor by means of the solution valve lever.

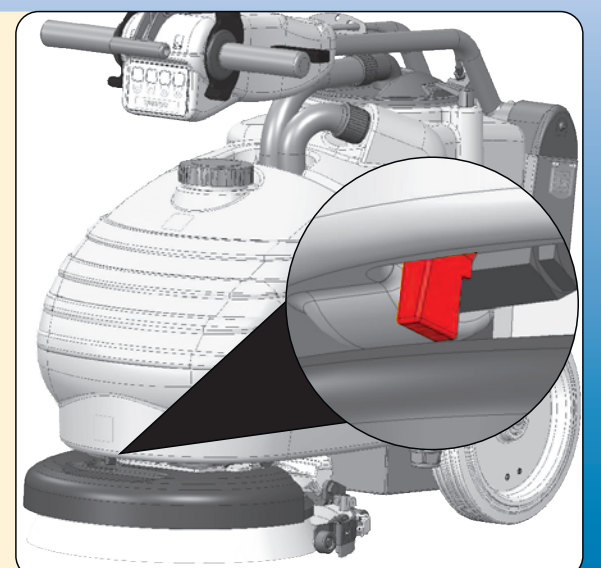

BEFORE USING THE MACHINE, READ CAREFULLY THE USE/MAINTENANCE MANUAL



SAFETY RULES

- During the operation of the machine, pay attention to other people and especially to the children.
- Do not damage the mains cable by squashing or bending.
- Check the integrity of the mains cable and in case of damage, stop the machine and replace the cable.
- Do not use the machine on surfaces covered with inflammable liquids or dusts (for example hydrocarbons, ashes or soot).
- In case of fire do not use water but a powder based fire-extinguisher.
- During maintenance operation use suitable individual protection devices (gloves, glasses, shoes).
- Signal the areas of moist floors.

BATTERIES:

- Do not place any metallic tools onto the batteries. Risk of short circuit!

Authorized dealer:

